

Case Report

Identification of a novel pre-terminating mutation in human HBB gene as a cause of β^0 -thalassemia phenotype

Liangpu Xu, Meihuan Chen, Hailong Huang, Na Lin, Lingji Chen, Yan Wang, Min Zhang, Deqin He, Yuan Lin

Fujian Provincial Maternity and Children's Hospital, Affiliated Hospital of Fujian Medical University, Fujian Key Laboratory for Prenatal Diagnosis and Birth Defects, Fuzhou 350001, China

Received March 17, 2019; Accepted May 22, 2019; Epub August 1, 2019; Published August 15, 2019

Abstract: Beta (β)-thalassemia (thal) is one of the most common genetic disorders of hemoglobin synthesis worldwide. Most cases of β -thal are caused by point mutations in hemoglobin subunit beta (HBB) gene, and only a minority of cases are caused by missing mutations of HBB gene. In this study, a 31-year-old pregnant woman with a typical thal phenotype was admitted at Fujian Provincial Maternity and Children's Hospital for prenatal diagnosis. Her father also presented with a typical thal phenotype, while the other members in the proband family were normal. Interestingly, Gap-PCR and reverse dot-blot hybridization assays showed that no mutation was found in the human HBA and HBB genes of the proband and her father. Subsequently, Sanger DNA sequencing identified a novel pre-terminating mutation, c.271 G>T [CD90 (GAG>TAG, Glu→stop codon)], in HBB gene from the proband and her father, while the other members in the proband family were normal. This mutation created a stop codon at amino acid 90 in exon 2 coding sequences of HBB gene, and led to a β^0 -thal phenotype. In summary, the present study is, to the best of our knowledge, the first to report a pre-terminating mutation, c.271 G>T [CD90 (GAG>TAG, Glu→stop codon)], in human HBB gene as a cause of β^0 -thal phenotype. This is important for clarifying the molecular mechanism of β^0 -thal and is useful for genetic counseling and prenatal screening.

Keywords: β -thal, HBB, phenotype, mutation, gene

Introduction

Beta (β)-thalassemia (thal) is one of the most common genetic disorders of hemoglobin synthesis worldwide, resulting in anemia due to reduced or abolished expression of the hemoglobin subunit beta gene (HBB) [1, 2]. To date, more than 200 mutations of HBB gene have been identified worldwide; among them, more than 40 mutations have been reported in the Chinese population [3]. The type and frequency of mutations vary with different ethnic groups and geographical locations [4]. Nonsense mutations and frameshift mutations tend to produce no β -globin chain (β^0 -thal), and splice mutations and promoter mutations tend to cause a reduction of β -globin chain (β^+ -thal) [5, 6]. The severity of β -thal is related to the different combinations of β^0 and β^+ -thal genotypes.

Most cases of β -thal are caused by point mutations of the HBB gene, and only a minority of

mutations is caused by missing mutations in HBB. In the Bangladeshi population, nearly 20 different mutations have been reported, and the number is continuously increasing [3, 7]. Five different mutations account for approximately 93.0% of the spectrum of β -thal in South Asian countries [8]. Gap-PCR and reverse dot-blot hybridization assays were used to detect the three deletional mutations (α^{-SEA} , $\alpha^{3.7}$ and $\alpha^{4.2}$) and the three nondeletional mutations ($\alpha^{OS}\alpha$, $\alpha^{CS}\alpha$, and $\alpha^{WS}\alpha$) in alpha (α)-thal, and the 17 known mutations in β -thal [9, 10]. Because of high heterogeneity of β -thal, there is a risk of missing a diagnosis of rare or novel mutation in HBB gene.

In this study, we report a 31-year-old pregnant woman with a typical thal phenotype with Hb 11.9 g/dL, MCV 66.6 fL, MCH 20.6 pg, HbA 87.7%, HbA2 5.0% and HbF 7.3%. Her father also showed a typical thal phenotype with Hb 10.8 g/dL, MCV 64.4 fL, MCH 20.5 pg, HbA

Identification of a novel pre-terminating mutation in HBB gene

92.2%, HbA2 4.6% and HbF 3.2%, while the other members in the proband family were normal. Gap-PCR and reverse dot-blot hybridization assays showed no mutation was found in the human hemoglobin subunit alpha (HBA) and (HBB) genes in the proband and her father. However, Sanger DNA sequencing identified a novel pre-terminating mutation, c.271 G>T [CD90 (GAG>TAG, Glu→stop codon)], in HBB gene from the proband and her father. This mutation created a stop codon at amino acid 90 in exon 2 coding sequences of HBB gene, and led to a β^0 -thal phenotype.

Materials and methods

Subject

A 31-year-old pregnant woman from Fujian Province of southern China was admitted for prenatal diagnosis. The proband showed hypochromic microcytic anemia and was in accordance with a typical phenotype of thal. Her father also presented with a thal phenotype, while the other members in the proband family were normal. Consent forms were signed from all members, and the research was conducted in accordance with the regulations of the Declaration of Helsinki (World Medical Association 1997). This study was also approved by the Ethic Committees of Fujian Provincial Maternity and Children's Hospital (No. 2017037).

Hematologic analysis

Peripheral blood (2 ml) from each family member was collected in our hospital. The number of red blood cells (RBC) and concentration of hemoglobin (Hb) were analyzed by an automated cell counter (XS-800i, Sysmex Co. Ltd., Japan). The levels of MCV (mean corpuscular volume), MCH (mean corpuscular hemoglobin), HbA (human hemoglobin alpha), HbA2 (human hemoglobin alpha 2), and HbF (human hemoglobin F) were analyzed by a Bio-Rad Variant II HPLC system (HPLC, VARIAN™, Bio-Rad, USA).

DNA isolation

Genomic DNA was extracted from peripheral blood by a commercially available DNA extraction kit (Qiagen, Hilden, Germany), according to the manufacturer's protocols. DNA was quantified by a NanoDrop 2000 Spectrophotometer (Thermo Fisher Scientific, MA, USA) to ensure

that DNA concentrations were greater than 100 ng/ μ l and that optical densities were between 1.8 and 2.0 at 260/280 nm. Finally, DNA was stored at -80°C for further experiments.

Reverse dot-blot hybridization (RDBH) assay

RDBH assay was used for detecting the 17 known mutations in β -thal, including codons 41/42 (-TCTT), IVS-II-654 (C>T), _28 (A>G), codons 71/72 (tA), codon 17 (A>T), Hb E [β 26 (B8) Glu-Lys, GAG>AAG or codon 26 (G>A)], codon 31 (-C), codons 27/28 (tC), codon 43 (G>T), _32 (C>A), _29 (A>G), _30 (T>C), codons 14/15 (tG), Cap t40 to t43 (-AAAC), initiation codon (T>G), IVS-I-1 (G>T) and IVS-I-5 (G>T), and the three nondeletional mutations in α -thal, including $\alpha^{QS}\alpha$, $\alpha^{CS}\alpha$, and $\alpha^{WS}\alpha$. Briefly, membrane-based DNA arrays were preincubated with hybridization buffer at 43°C for 2 h, and subsequently incubated in hybridization buffer with addition of 2 ng/ μ L denatured PCR products at 43°C for 30 min. After removing the redundant single-stranded products by washing with a series of buffers, the membrane strips were incubated with anti-DIG antibody conjugated with alkaline phosphatase at 37°C for 30 min. Again washing with a series of washing buffers, the strips were incubated with NBT (Nitrotetrazolium blue chloride) and BCIP (5-Bromo-4-Chloro-3-Indolyl Phosphate) to produce colored dots.

Gap-polymerase chain reaction (gap-PCR) assay

Gap-PCR assay was used to screen for the three deletional mutations in α -thal, including α^{SEA} , $\alpha^{3.7}$ and $\alpha^{4.2}$. The conditions were as follows: 25 μ l reaction contained 200 mM dNTP, 1.5 mM MgCl₂, 1 \times Q-solution, 2.5 U HotStarTaq DNA polymerase, 100 ng DNA, and 0.5 μ M primers. Reaction was conducted in a T3 thermal cycler (Biometra GmbH, Germany), with an initial denaturation at 95°C for 10 min, followed by 35 cycles of 98°C denaturation for 45 s, annealing at 66°C for 30 s, extension at 72°C for 3 min, and final extension at 72°C for 10 min. 1.5% agarose gel electrophoresis was applied to detect PCR products.

Sanger DNA sequencing

PCR (Polymerase chain reaction) assay was used to amplify total length of the HBB gene

Identification of a novel pre-terminating mutation in HBB gene

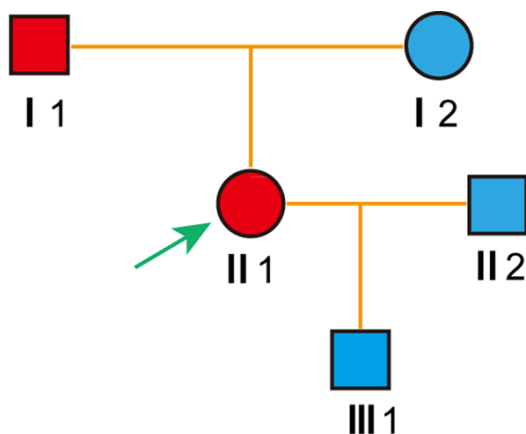

Figure 1. The pedigree of the proband family. The arrow indicates the proband. I1: Father, I2: Mother, II1: Proband, II2: Husband, III1: Son.

in all members of the family. The primers were as follows: 5'-GTACGGCTGTCACCTTAGACCTCA-3' (forward) and 5'-TTTCCCAAGGTTTGAACTAGCTCTT-3' (reverse). The reaction volume contained 150 ng DNA, 0.4 μ M of forward and reverse primers, 0.2 mM dNTP, 5 μ l 10 \times PCR buffer and 2 U Taq polymerase. The amplification conditions were: an initial denaturation at 95°C for 5 min, followed by 35 cycles of 98°C for 45 s, 66°C for 45 s and 72°C for 3 min, with a final elongation step at 72°C for 10 min. The PCR products were segregated by using 2% agarose gel electrophoresis and sequenced by using a BigDyeTM Terminator Cycle Sequencing Kit (Applied Biosystems, Foster City, CA, USA) on the ABI PRISMTM 3130 Genetic Analyzer (Applied Biosystems, Foster City, CA, USA).

Statistical analysis

SPSS software version 19.0 (SPSS, Chicago, IL, USA) was applied for statistical analysis. Data were presented as the mean \pm standard deviation (SD). A value of $P < 0.05$ was considered a significant difference. Analysis of variance (ANOVA) followed by post hoc tests or Student's t-test was used to analyze the differences between groups.

Results

Hematologic features of the proband family

The pedigree of the proband family is shown in **Figure 1**. The hematologic analysis of the members is presented in **Table 1**. The proband showed a hypochromic microcytic anemia with Hb 11.9 g/dL, MCV 66.6 fL and MCH 20.6 pg,

HbA 87.7%, HbA2 5.0% and HbF 7.3%, which was in accordance with a typical thal phenotype. Her father also showed a typical thal phenotype with Hb 10.8 g/dL, MCV 64.4 fL, MCH 20.5 pg, HbA 92.2%, HbA2 4.6%, and HbF 3.2%, while the other members in the family were normal.

Analysis of known mutations in the proband family

Gap-PCR and reverse dot-blot hybridization assay were used to detect the three deletional mutations and nondeletional mutations in α -thal, and the 17 known mutations in β -thal. As shown in **Figure 2**, a 1.8 kb normal DNA fragment was observed in all members of the proband family, indicating the members were not carriers of deletional mutations. RDBH assay showed that the three nondeletional mutations (**Figure 3**) and the 17 known mutations (**Figure 4**) were also not detected from all members of the proband family. These data indicated that the thal phenotype may be caused by a novel mutation, that could not be identified by routine screening.

Identification of a novel pre-terminating mutation in human HBB gene as a cause of β^0 -thalassemia phenotype

Subsequently, we applied a PCR assay to amplify the total length of human HBB gene. The PCR products were sequenced by using a BigDyeTM Terminator Cycle Sequencing Kit on the ABI PRISMTM 3130 Genetic Analyzer. As shown in **Figure 5**, we found a novel pre-terminating mutation, c.271 G>T [CD90 (GAG>TAG, Glu \rightarrow stop codon)], in HBB gene from the proband and her father. This mutation created a stop codon at amino acid 90 in exon 2 coding sequences of HBB gene, and led to a β^0 -thal phenotype. The other members in the proband family did not have this mutation.

Discussion

β -thal is a common autosomal recessive hereditary hematologic disease characterized by reduced or abolished expression of the β -globin chain. Human HBB gene is located at 11p15.3 and encodes the β -globin chain. Patients with β -thal have point and missense mutations in HBB gene and present with chronic hemolytic anemia phenotype [11]. β -thal is classified into

Identification of a novel pre-terminating mutation in HBB gene

Table 1. The hematologic features of the proband family

Member	Age (years)	RBC ($10^{12}/L$)	Hb (g/L)	MCV (fL)	MCH (pg)	HbA (%)	HbA2 (%)	HbF (%)
Father I1	60	5.28	108	64.40	20.50	92.2	4.6	3.2
Mother I2	54	4.18	127	90.70	30.40	97.5	2.5	0
Proband II1	31	5.78	119	66.60	20.60	87.7	5.0	7.3
Husband II2	37	5.63	162	86.70	28.80	97.1	2.9	0
Son III1	10	4.92	133	81.50	27.00	97.2	2.8	0

RBC: Red blood cells, Hb: hemoglobin, MCV: mean corpuscular volume, MCH: mean corpuscular hemoglobin, HbA: human hemoglobin alpha, HbA2: human hemoglobin alpha 2, HbF: human hemoglobin F.

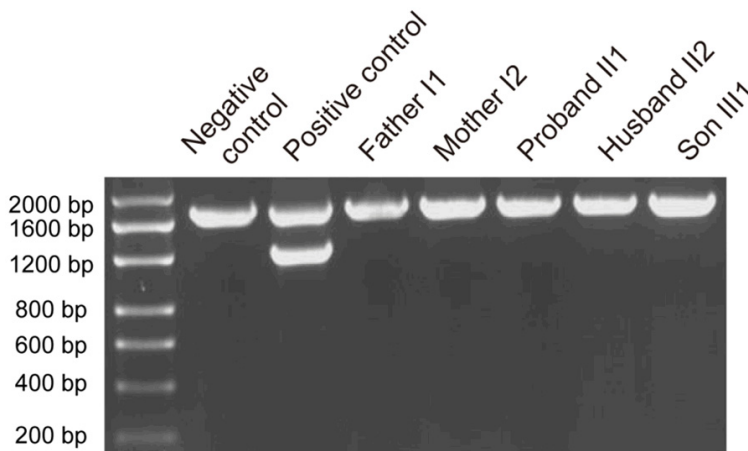

Figure 2. The analysis of the three deletional mutations ($-^{SEA}$, $\alpha^{3.7}$ and $\alpha^{4.2}$) in alpha (α)-thalassemia (thal) from the proband family by using a Gap-PCR assay. Positive control: $-^{SEA}/\alpha\alpha$, Negative control: $\alpha\alpha/\alpha\alpha$.

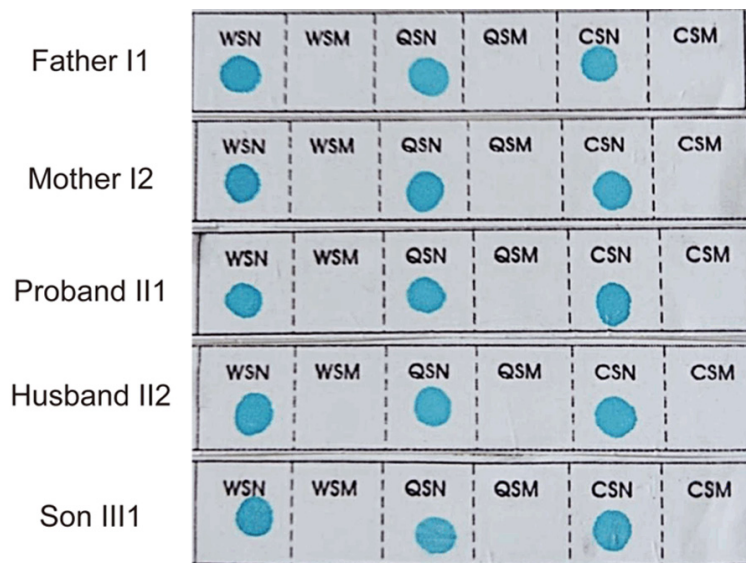

Figure 3. Reverse dot-blot hybridization (RDBH) assay analysis of the $\alpha^{CS}\alpha$, $\alpha^{CS}\alpha$, and $\alpha^{WS}\alpha$ mutations from the proband family. WSN, QSN and CSN were the normal probes, while WSM, QSM and CSM were the mutant probes.

two different phenotypes: β^+ -thal (reduction of β -globin chain) and β^0 -thal (absence of β -globin chain). β -thal is a very serious blood disorder because most patients are unable to make enough healthy red blood cells and require continual blood transfusions throughout their lives [12]. Various complications may accompany β -thal, including progressive liver failure, abnormal kidney function, endocrine dysfunction and growth retardation, which may have a serious impact on the patient's quality of life, and many patients die in adolescence [13, 14]. Therefore, it is crucial to identify and prevent β -thal by improving our knowledge of its etiology.

In this study, a 31-year-old pregnant woman was admitted to the Fujian Provincial Maternity and Children's Hospital for prenatal diagnosis. The proband showed hypochromic microcytic anemia with Hb 11.9 g/dL, MCV 66.6 fL, MCH 20.6 pg, HbA 87.7%, HbA2 5.0% and HbF 7.3%, which was in accordance with a hematologic phenotype of thal. Her father had also a hematological thal phenotype with Hb 10.8 g/dL, MCV 64.4 fL, MCH 20.5 pg, HbA 92.2%, HbA2 4.6% and HbF 3.2%. Other members in the proband family had normal hematologic parameters. However, no mutation was found from all members of the family by using Gap-PCR and reverse dot-blot hybridization assays. These data indicated that the thal phenotype may be caused by a novel mutation, which could not be identified by routine screening. Then, in order to identify an unknown mutation, we applied PCR to amplify the total length of human HBB gene of all members. PCR pr-

Identification of a novel pre-terminating mutation in HBB gene

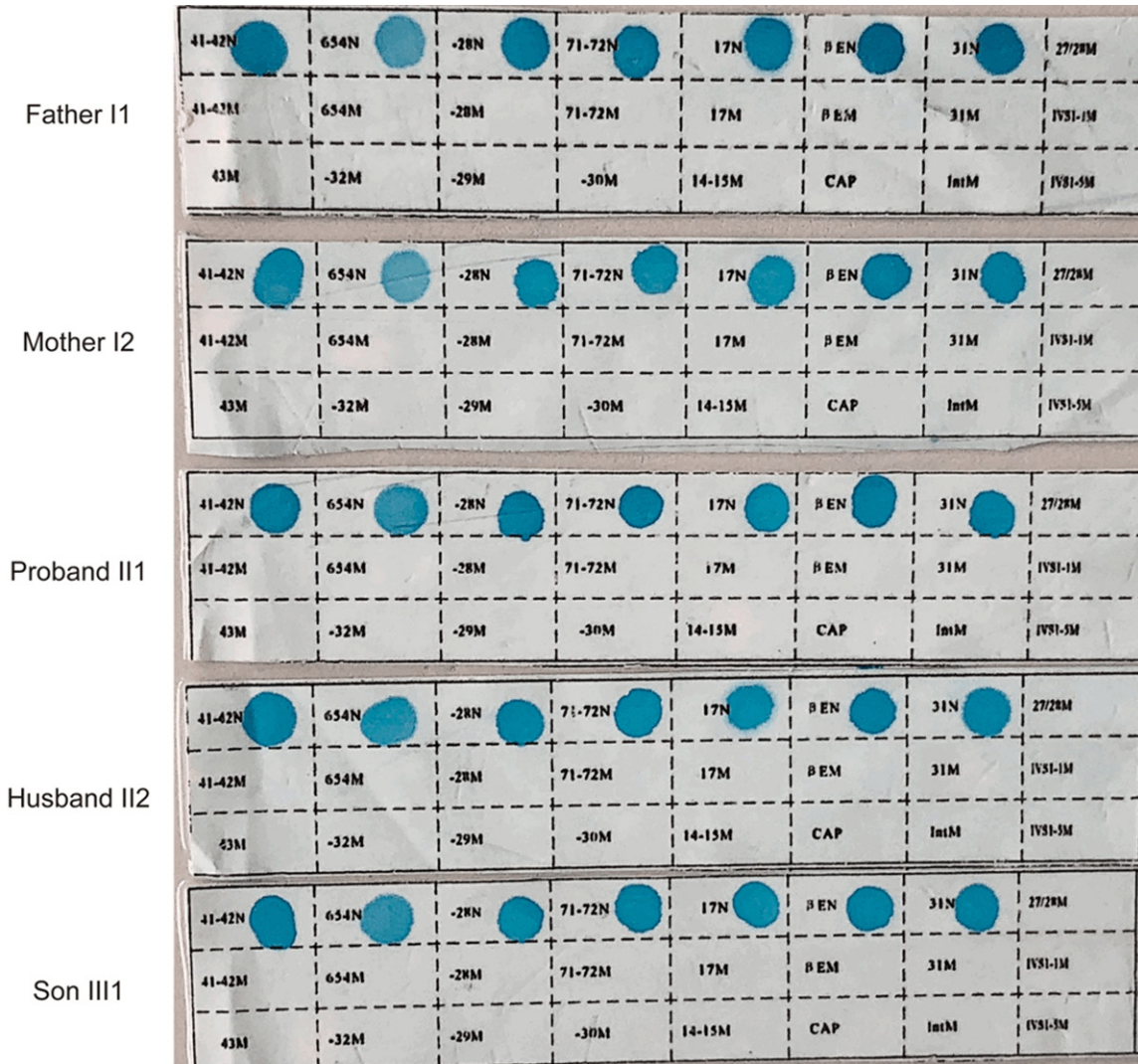

Figure 4. RDBH assay analysis of the 17 known mutations in beta (β)-thal the proband family. N indicated the normal probes, while M indicated the mutant probes. 41-42M: codons 41/42 (-TCTT), 43M: codon 43 (G>T), 654M: IVS-II-654 (C>T), -23M: $_32$ (C>A), -28M: $_28$ (A>G), -29M: $_29$ (A>G), 71-72M: codons 71/72 (tA), -30M: $_30$ (T>C), 17M: codon 17 (A>T), 14-15M: codons 14/15 (tG), β EM: Hb E [β 26 (B8) Glu-Lys, GAG>AAG or codon 26 (G>A)], CAP: Cap t40 to t43 (-AAAC), 31M: codon 31 (-C), IntM initiation codon (T>G), 27/28M: codons 27/28 (tC), IVS-I-1M: IVS-I-1 (G>T), IVS-I-5M: IVS-I-5 (G>T).

oducts were sequenced by using the BigDyeTM Terminator Cycle Sequencing Kit. Interestingly, we identified a novel pre-terminating mutation, c.271 G>T [CD90 (GAG>TAG, Glu→stop codon)], in HBB gene from the proband and her father. This mutation created a stop codon at amino acid 90 in exon 2 coding sequences of the HBB gene, and led to a β^0 -thal phenotype. The other members in the family showed no mutation in HBB gene.

There are many different types of mutations involved in the HBB gene cluster, resulting in

different phenotypes. Mutations occurring in exon, intron and promoter regions may change translation, impact RNA processing, and cause abnormal transcription, respectively [15]. Here, we first report c.271 G>T [CD90 (GAG>TAG, Glu→stop codon)] mutation in human HBB gene, which is the fifth mutation reported in exon 2 of HBB gene. Other reported mutations in exon 2 are HBB: c.271 G>A [CD90 (GAG>AAG, Glu→Lys)] [16], HBB: c.272 A>G [CD90 (GAG>GGG, Glu→Gly)] [17], HBB: c.273 G>C [CD90 (GAG>GAC, Glu→Asp)] [18], and HBB: c.271 G>C [CD90 (GAG>CAG, Glu→Gln)] [19]. The

Identification of a novel pre-terminating mutation in HBB gene

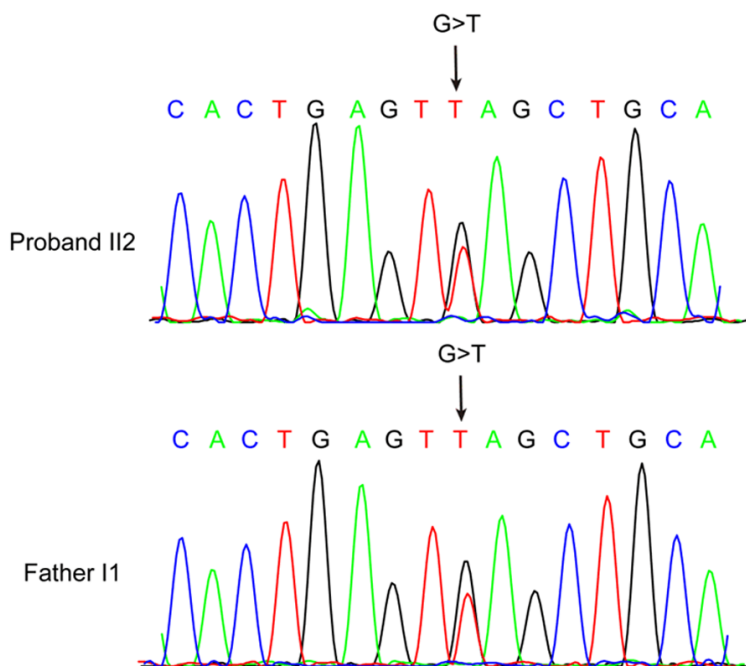

Figure 5. Sequence analysis of the total length of human HBB gene from the proband and her father. The arrows indicate the mutant sites.

ninetieth amino acid is external and is not involved in the contact or in the heme pocket, and no obvious changes are observed in the hematologic phenotype of the four mutations, except for a slight change in the affinity of oxygen. In our study, a novel pre-terminating mutation changed Glu into a stop codon, resulting in premature termination of peptide synthesis and lack of the beta protein, and led to a β^0 -thal phenotype.

Taken together, our report first identified a novel pre-terminating mutation, c.271 G>T [CD90 (GAG>TAG, Glu→stop codon)], in the human HBB gene as a cause of β^0 -thal phenotype. This finding is useful for genetic counseling and prenatal diagnosis of β^0 -thal carriers, as well as increasing the understanding of gene expression and regulation of HBB gene.

Acknowledgements

This work was supported by the Key Special Projects of Fujian Provincial Department of Science and Technology (No. 2013YZ0002-1), the Key Clinical Specialty Discipline Construction Program of Fujian (No. 20121589) and The Fujian Provincial Natural Science Foundation (No. 2017J01238).

Disclosure of conflict of interest

None.

Address correspondence to: Yuan Lin, Fujian Provincial Maternity and Children's Hospital, Affiliated Hospital of Fujian Medical University, Fujian Key Laboratory for Prenatal Diagnosis and Birth Defects, No. 18 Daoshan Road, Gulou District, Fuzhou 350001, China. Tel: (86)-591-87554929; E-mail: alice-96@163.com

References

- [1] Viprakasit V and Ekwatanakit S. Clinical classification, screening and diagnosis for thalassemia. *Hematol Oncol Clin North Am* 2018; 32: 193-211.
- [2] Mettananda S and Higgs DR. Molecular basis and genetic modifiers of thalassemia. *Hematol Oncol Clin North Am* 2018; 32: 177-191.
- [3] Aziz A, Das SA, Khan WA, Sadiya S, Banu B, Sarwardi G and Luna RZ. A novel beta-thalassemia insertion/frameshift mutation between codons 77/78 (p.Leu78Profs*13 or HBB: c.235_236insC) observed in a family in Bangladesh. *Hemoglobin* 2017; 41: 311-313.
- [4] Modell B and Darlison M. Global epidemiology of haemoglobin disorders and derived service indicators. *Bull World Health Organ* 2008; 86: 480-487.
- [5] Origa R. β -Thalassemia. *Genet Med* 2017; 19: 609-619.
- [6] Jiang F, Chen GL, Zhou JY and Li DZ. First report of the rare IVS-II-705 (T>G) beta-thalassemia mutation in a Chinese family. *Hemoglobin* 2017; 41: 286-287.
- [7] Giardine B, Borg J, Viennas E, Pavlidis C, Moradkhani K, Joly P, Bartsakoulia M, Riemer C, Miller W, Tzimas G, Wajcman H, Hardison RC and Patrinos GP. Updates of the HbVar database of human hemoglobin variants and thalassemia mutations. *Nucleic Acids Res* 2014; 42: D1063-1069.
- [8] Varawalla NY, Old JM, Sarkar R, Venkatesan R and Weatherall DJ. The spectrum of beta-thalassaemia mutations on the Indian subcontinent: the basis for prenatal diagnosis. *Br J Haematol* 1991; 78: 242-247.
- [9] Lin M, Zhu JJ, Wang Q, Xie LX, Lu M, Wang JL, Wang CF, Zhong TY, Zheng L, Pan MC, Wu JR,

Identification of a novel pre-terminating mutation in HBB gene

- Wen YF, Liu GR, Zhan XF, Lin F and Yang LY. Development and evaluation of a reverse dot blot assay for the simultaneous detection of common alpha and beta thalassemia in Chinese. *Blood Cells Mol Dis* 2012; 48: 86-90.
- [10] Zhang J, Zhu BS, He J, Zeng XH, Su J, Xu XH, Li SY, Chen H and Zhang YH. The spectrum of alpha-and beta-thalassemia mutations in Yunnan Province of Southwestern China. *Hemoglobin* 2012; 36: 464-473.
- [11] Weatherall DJ. Phenotype-genotype relationships in monogenic disease: lessons from the thalassaemias. *Nat Rev Genet* 2001; 2: 245-255.
- [12] Kountouris P, Lederer CW, Fanis P, Feleki X, Old J and Kleanthous M. IthaGenes: an interactive database for haemoglobin variations and epidemiology. *PLoS One* 2014; 9: e103020.
- [13] Nemtsas P, Arnaoutoglou M, Perifanis V, Koutsouraki E, Spanos G, Arnaoutoglou N, Chalkia P, Pantelidou D and Orogas A. Polyneuropathy and myopathy in beta-thalassemia major patients. *Ann Hematol* 2018; 97: 899-904.
- [14] Fibach E and Rachmilewitz EA. Pathophysiology and treatment of patients with beta-thalassemia - an update. *F1000Res* 2017; 6: 2156.
- [15] Mahdavi MR, Karami H, Akbari MT, Jalali H and Roshan P. Detection of rare beta globin gene mutation [+22 5UTR(G>A)] in an infant, despite prenatal screening. *Case Rep Hematol* 2013; 2013: 906292.
- [16] Miyaji T, Suzuki H, Ohba Y and Shibata S. Hemoglobin agenogi (alpha 2 beta 2-90Lys), a slow-moving hemoglobin of a Japanese family resembling Hb-E. *Clin Chim Acta* 1966; 14: 624-629.
- [17] Merault G, Keclard L, Saint-Martin C, Jasmin K, Campier A, Delanoe-Garin J, Arous N, Fortune R, Theodore M, Seytor S, et al. Hemoglobin Roseau-Pointe a Pitre alpha 2 beta 2(90) (F6) Glu—Gly: a new hemoglobin variant with slight instability and low oxygen affinity. *FEBS Lett* 1985; 184: 10-13.
- [18] Baklouti F, Giraud Y, Francina A, Richard G, Favre-Gilly J and Delaunay J. Hemoglobin Pierre-Benite [beta 90(F6)Glu—Asp], a new high affinity variant found in a French family. *Hemoglobin* 1988; 12: 171-177.
- [19] Cai WJ, Xie XM, Zhang YL, Li R, Liao C and Li DZ. A new hemoglobin variant: Hb Henan [beta90(F6)Glu→Gln; HBB: c.271 G<C]. *Hemoglobin* 2014; 38: 127-129.